

Control Valve Module M700

Tank Selection Valve Systems
Integrated Monitoring and Control



General Description

The M700 Control Valve Modules provides safe, reliable, and monitored flow control for multi-tank fuel systems. The control valves are pre-assembled with integral controller to assure that supply and return paths to storage tanks are always in synch. The modules are also equipped with pressure relief devices to control thermal expansion issues in pipelines.

Performance Characteristics include:

- Full Port Ball valves for High Flow and Tight Shutoff
- Valve Actuators with limit switches for position monitoring
- PLC control for Valve Alignment Check and Alarm on Error
- Visual Valve Position Indicators
- Manual valve Position Over-ride Function
- Pressure Relief Valves for Pipeline Thermal Expansion Relief
- Maintains Open Path for Overflows to Bulk Tanks

The system is adaptable for either:

- Suction Systems using Positive Displacement Pumps: Control Valves are provided for both Fuel Oil Supply (FOS) and Fuel Oil return (FOR) Piping
- Pressure Systems using Submersible Fuel Supply Pumps: Control Valves are for Fuel Oil Return (FOR) flows only

Control Valve Module M700

Tank Selection Valve Systems
Integrated Monitoring and Control

Ordering Information

M700.M.NN,XX.YY
Control Valve Module

M FOS Valve Count (1-4)
NN FOS Valve Size
(25-38-50-75-100)

X FOR Valve Count
YY FOR Valve Size

M700 Control Valve Module

Dimensions	760L x 460W x 1500H
Flow Capacity GPM	Up to 560 LPM
Sizes	2-8 Valves 25-100 Valve Size
Valves	Full Port Ball Valves Carbon Steel Bodies with Stainless Steel Trim Teflon Seats and Seals 3 Piece Construction
Connections	25 MNPT Threaded, Socket Weld, or Flange 38 MNPT Threaded, Socket Weld or Flange 50 MNPT Threaded, Socket Weld or Flange 75 Socket Weld or Flange 100 Socket Weld or Flange
Valve Actuators	IP55 Enclosure (Optional x-Proof) 120 VAC Power Open and Close Limit Switches Visual Position Indicator Manual Position Over-ride
Accessories	Pressure Relief Devices for Pipe 340 kPa Standard Setting
Construction	Welded Steel Construction Integral Containment Basin 25 Liter Industrial Enamel Finish Color RAL7035 Light Gray Optional Weatherproof Enclosure
Controls	C820 OmniPlex Controller or C900 CentraPlex Master Controller
Optional Equipment	01 Weatherproof Enclosure 02 Less OmniPlex Controller (CentraPlex System Control) 03 Flow Sensors 04 Pressure Sensors

Control Valve Module M700

Tank Selection Valve Systems
Integrated Monitoring and Control

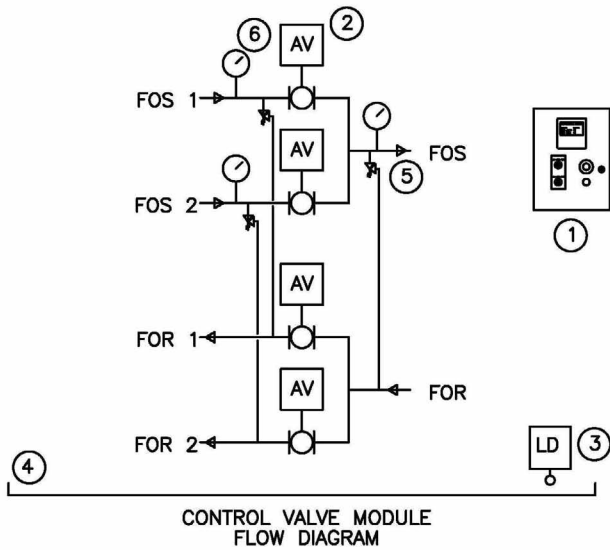

Multi-Tank Selection:

The control panel monitors pump sets for a pump on signal. The panel energizes the FOS and FOR valves from the primary fuel supply tank, and receives an open limit switch signal to prove operation. When the pump on signal ceases, then the FOS and FOR valves from the primary tank are closed.

The control panel display allows the selection of the primary and secondary tank status. The operation will switch to the alternate tank if a low level signal is received for the primary tank. The low level signal can be generated by an independent sensor, or from a tank level gauge output signal.

The display indicates for each tank: (a) lead / lag status, (b) normal / alarm status, (c) valve open / close status, (d) not-in-auto status. A common alarm output relay and a serial data interface are provided for BMS integration.

MARK	QTY	DESCRIPTION
1	1	OMNIPLEX CONTROL PANEL
2	1	ACTUATED BALL VALVE
3	1	LEAK SENSOR
4	1	PUMP CONTAINMENT
5	1	PRESSURE RELIEF VALVE
6	1	PRESSURE / VACUUM GAUGE

Earthsafe Systems, Inc.
7553 S. Madison
Willowbrook, IL 60527

T: (630) 794-5100
F: (630) 794-5106

info@earthsafe.com
www.earthsafe.com