

## MP2T

### MP2T: Genset Oil Change Unit on Trailer

Specifically designed for lube oil change of generators. The MP2B is designed for distributed generators and campus environments. 50 feet hose reels for supply and waste tubing allow clean simple operation.

2 Positive Displacement Pumps deliver fresh and waste oil to the generator. Pumps also reverse flow to onboard fresh oil and discharge waste oil from totes or tanks.

- High suction variable speed pump with flow meter
- Sensors for flow, tank level, and leak
- PLC with HMI Interface

Low Power Design, 12A at 120VAC for Standard Plug-In

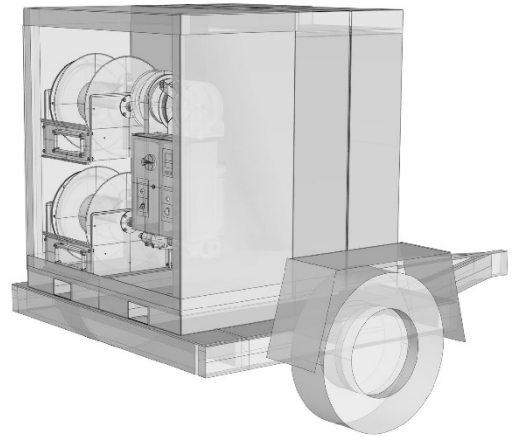

<b>Dimensions</b>	84" W x 60" H x 96" L (1000W x 1500H x 2400D)
<b>Flow Capacity</b>	10 GPM (40 LPM) 600 GAL per Hour
<b>Pressure Capacity</b>	Standard 25 PSI Max. 100 PSI (690kPa)
<b>Pump Type</b>	Positive Displacement Viking H475 Series
<b>Tanks</b>	100/100 GAL Fresh/Waste Oil Aluminum Construction 50/50, 150/150, and 200/200 GAL Combination are Available
<b>Weight (Estimate)</b>	1000 LB (450 KG) Empty 2500 LB (1100 KG) Operating
<b>Standard Accessories)</b>	50 FT Supply + Waste Hoses Spring Rewind Hose Reel 100 FT Power Cord Reel 50 FT Grounding Cable Reel Flow Meter - Electronic Holding Tank Level and High
<b>Construction</b>	Welded Aluminum Containment Basin Forklift Pockets

<b>Motor</b>	TEFC (IP 55)
<b>Power</b>	120-230 VAC, 1P, 50-60 Hz 12 A at 120 VAC
<b>Controller</b>	C8+C2V Controller
<b>Operators</b>	On-Off Pump Pushbuttons Auto-Stop on Time or Flow
<b>Interface</b>	Weatherproof Color HMI Display Flow Rate, Flow Total, Tank Level and GAL
<b>Communication (Optional)</b>	CANbus Output to Cellular Cloud Based Report Mgmt
<b>Optional Accessories</b>	Insulated Heated Enclosure SS Enclosure
<b>How to Order</b>	MP2T Genset Oil Change Unit on Trailer